

集水柵

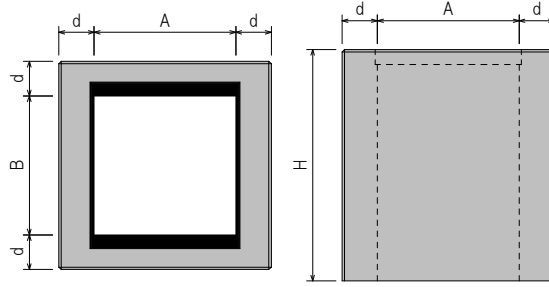

呼び名	寸法 (mm)			
	A	B	d	H
300×300	300	300	100	300~800
	300	300	150	300~800
400×400	400	400	150	400~1000
450×450	450	450	150	450~1600
500×500	500	500	150	500~1800
600×600	600	600	150	600~1500

呼び名	寸法 (mm)			
	A	B	d	H
700×700	700	700	150	700~1800
	700	700	200	700~1800
800×800	800	800	150	800~1500
	800	800	200	800~1800
900×900	900	900	150	900~1500
	900	900	200	900~1500
1000×1000	1000	1000	150	1000~1600
	1000	1000	200	1000~1600

※グレーチングに関しては、各種対応が可能です。

街渠柵

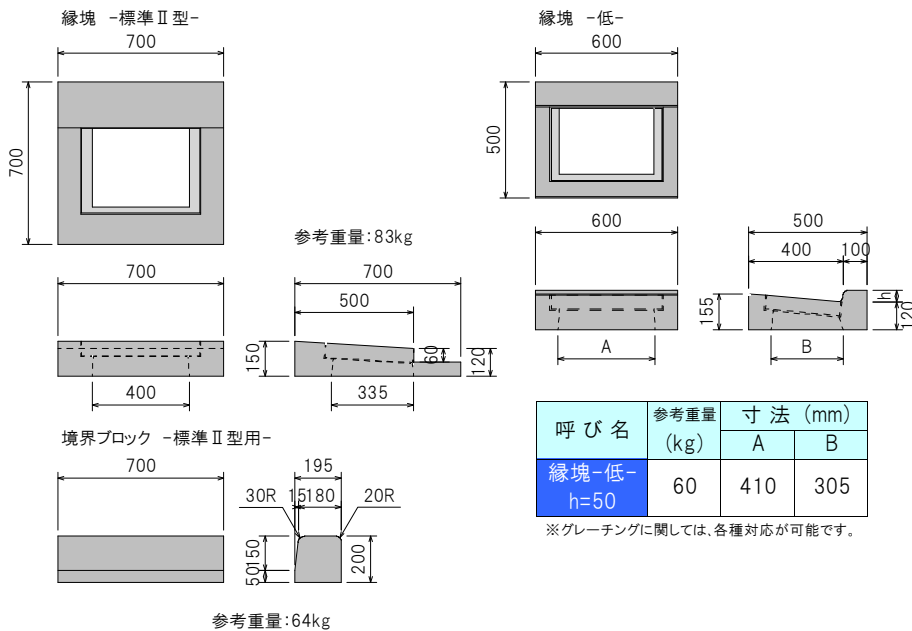

呼び名	参考重量 (kg)	寸法 (mm)	
		A	B
縁塊-低-h=50	60	410	305

※グレーチングに関しては、各種対応が可能です。

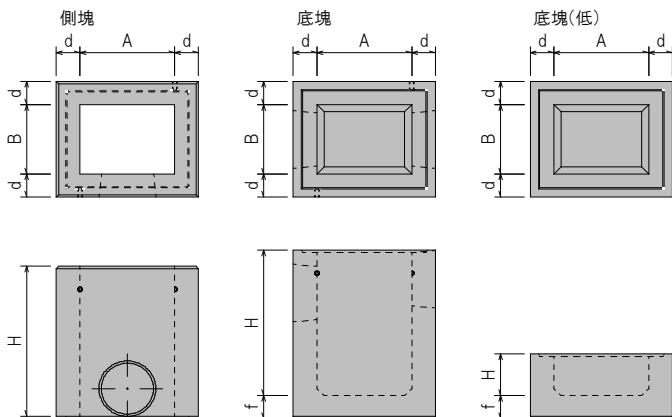

呼び名	参考重量 (kg)	寸法 (mm)					
		A	B	H	d	f	
側塊	400×300	310	400	300	670	100	—
底塊	400×300	318	400	300	655	100	100
底塊(低)	400×300	125	400	300	160	100	100
側塊	400×400	554	400	400	715	150	—
底塊	400×400	636	400	400	615	150	150
底塊(低)	400×400	265	400	400	115	150	150

○900×900, 1000×1000, 1500×1500

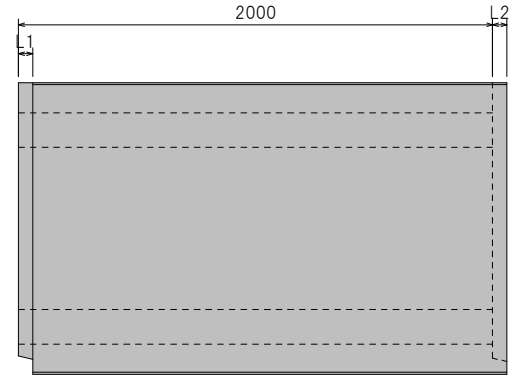
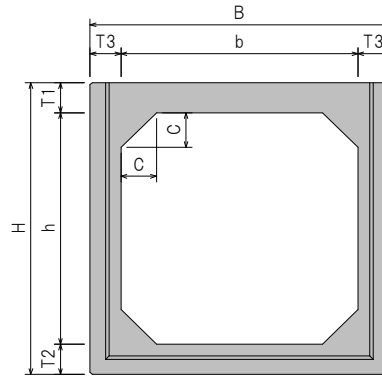
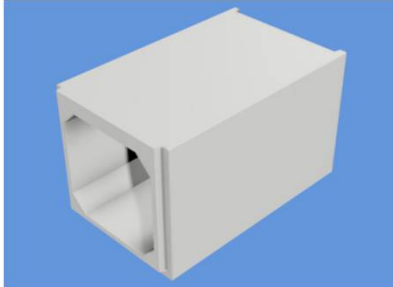

○上記のサイズ以外

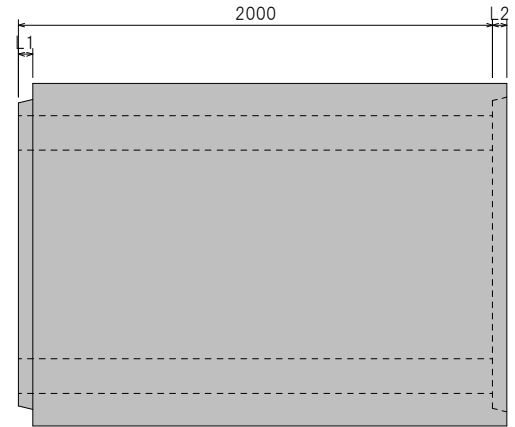
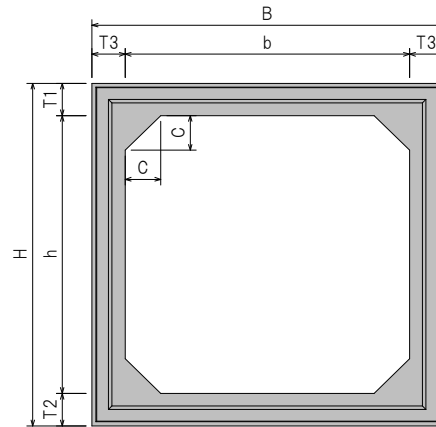
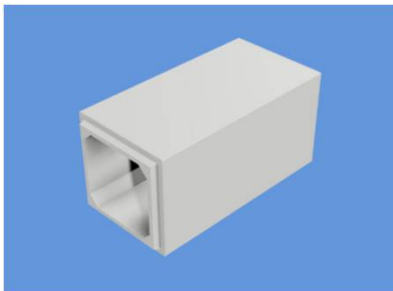

呼び名	参考重量 (kg)	寸法 (mm)									
		B	H	b	h	T1	T2	T3	C	L1	L2
600×900	2190	840	1140	600	900	120	120	120	100	60	60
900×600	2190	1140	840	900	600	120	120	120	100	60	60
900×900	2666	1160	1160	900	900	130	130	130	100	60	40
1000×800	2670	1240	1040	1000	800	120	120	120	150	60	60
1000×1000	3036	1260	1260	1000	1000	130	130	130	150	60	60
1200×800	3420	1480	1080	1200	800	140	140	140	150	60	60
1200×1000	3700	1480	1280	1200	1000	140	140	140	150	60	60
1200×1200	3980	1480	1480	1200	1200	140	140	140	150	60	60
1300×1300	4100	1560	1580	1300	1300	140	140	130	150	60	60
1400×1400	4540	1660	1700	1400	1400	150	150	130	150	60	60
1500×1000	4470	1780	1320	1500	1000	160	160	140	150	60	60
1500×1200	4750	1780	1520	1500	1200	160	160	140	150	60	60
1500×1500	5170	1780	1820	1500	1500	160	160	140	150	60	60

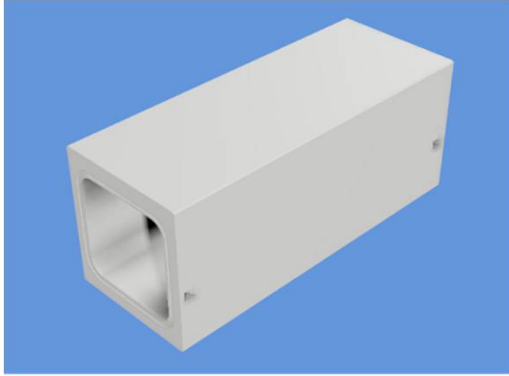

○内幅250~600

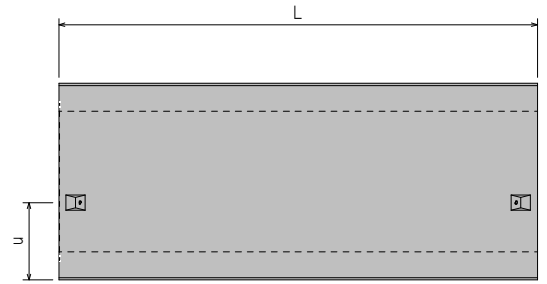
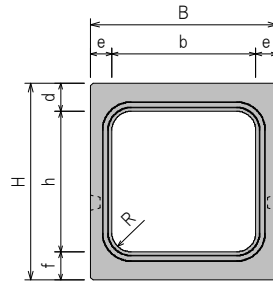

○内幅700~1000

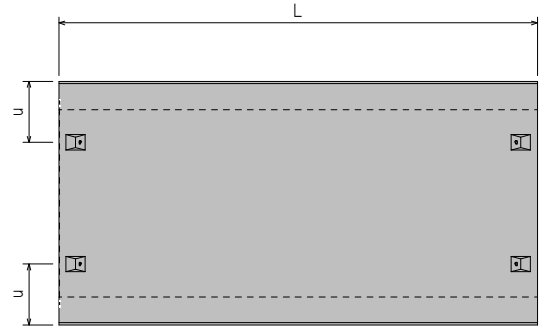
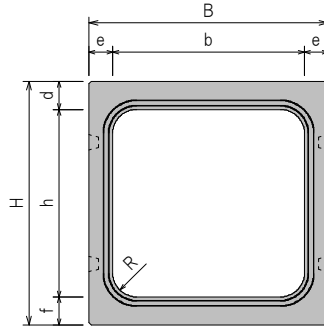

呼び名	参考重量 (kg)	寸法 (mm)									
		B	H	b	h	L	d	e	f	R	u
250×250	365	350	390	250	250	2000	70	50	70	50	150
300×300	510	420	460	300	300	2000	80	60	80	60	180
300×400	568	420	560	300	400	2000	80	60	80	60	220
350×350	671	480	540	350	350	2000	95	65	95	60	210
400×400	802	540	600	400	400	2000	100	70	100	70	240
400×230	647	520	430	400	230	2000	100	60	100	60	170
400×500	875	540	700	400	500	2000	100	70	100	70	280
450×450	949	600	660	450	450	2000	105	75	105	70	260
500×500	1101	660	720	500	500	2000	110	80	110	80	280
600×600	1437	780	840	600	600	2000	120	90	120	80	330
700×700	1749	900	940	700	700	2000	120	100	120	100	235
800×800	1960	1000	1040	800	800	2000	120	100	120	100	260
900×900	2388	1120	1160	900	900	2000	130	110	130	100	290
1000×1000	2619	1220	1260	1000	1000	2000	130	110	130	100	315

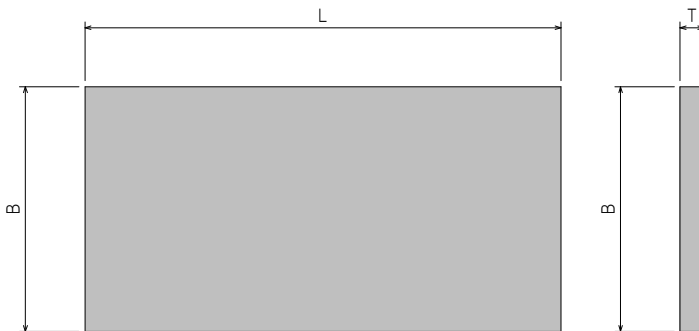

呼び名	参考重量 (kg)	寸法 (mm)		
		B	L	T
250用	293	610	2000	100
300用	317	660	2000	100
350用	360	750	2000	100
400用	384	800	2000	100
450用	408	850	2000	100
500用	432	900	2000	100
600用	509	1060	2000	100
700用	557	1160	2000	100
800用	605	1260	2000	100
900用	653	1360	2000	100
1000用	701	1460	2000	100

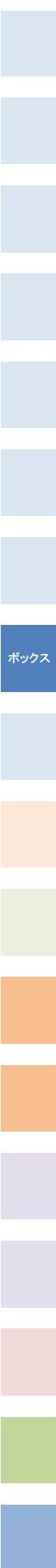

ボックス