

ーアーバンU-V 施工例ー

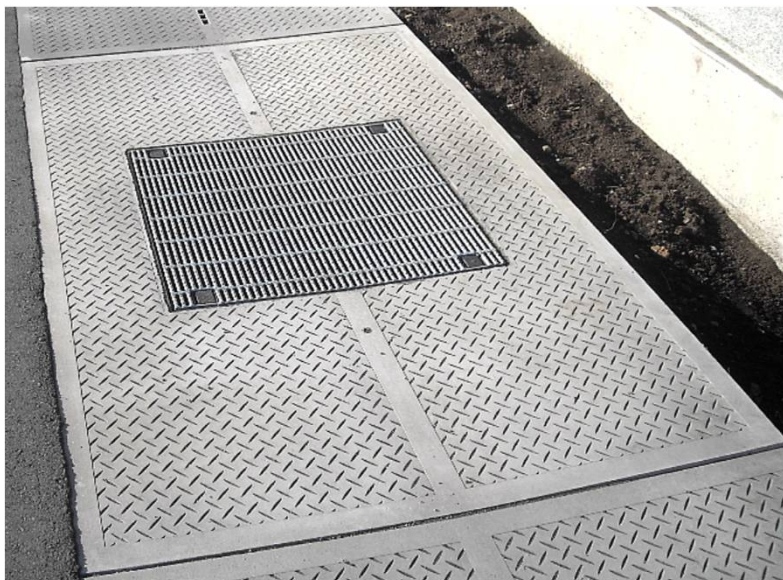

ーアーバンU-V 施工例ー



ーアーバンU 施工例ー

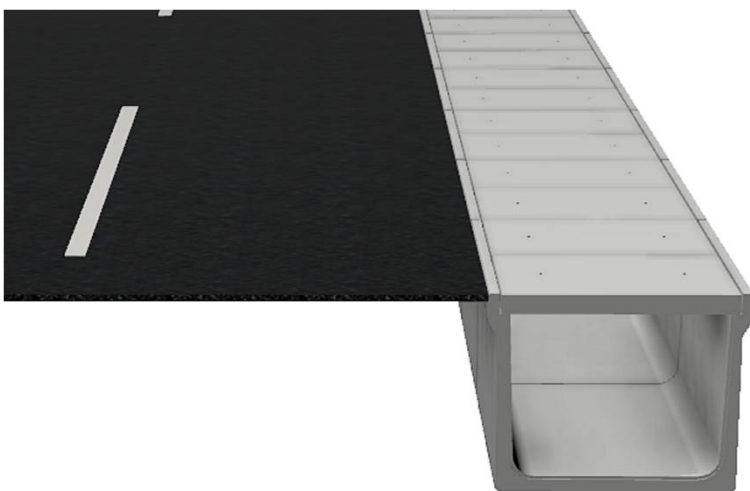

都市型
水路

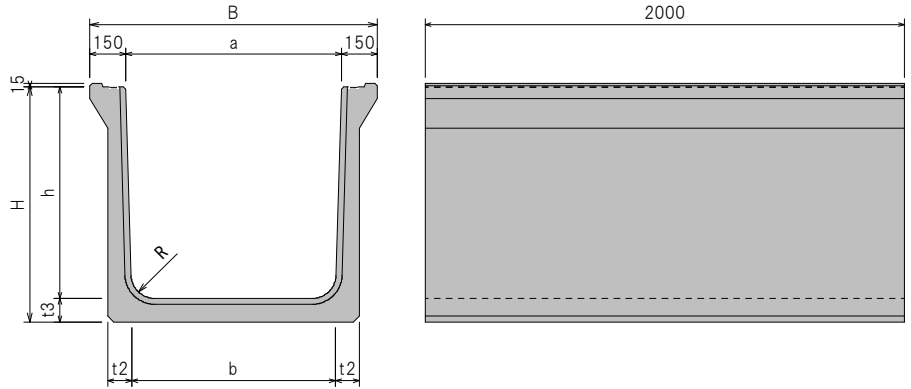
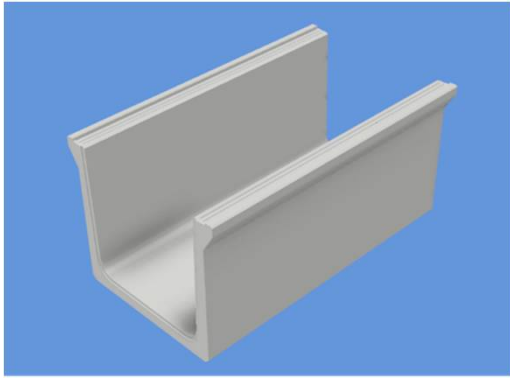

呼び名	参考重量 (kg)	寸法 (mm)							
		B	H	a	h	b	t2	t3	R
700×700	1049	1000	795	700	700	650	95	95	100
700×800	1127	1000	895	700	800	650	95	95	100
800×800	1174	1100	895	800	800	750	95	95	100
800×900	1315	1100	1000	800	900	750	100	100	100
900×900	1363	1200	1000	900	900	850	100	100	100
1000×1000	1622	1300	1110	1000	1000	930	110	110	150
1200×1500	3201	1500	1660	1200	1500	1100	160	160	250

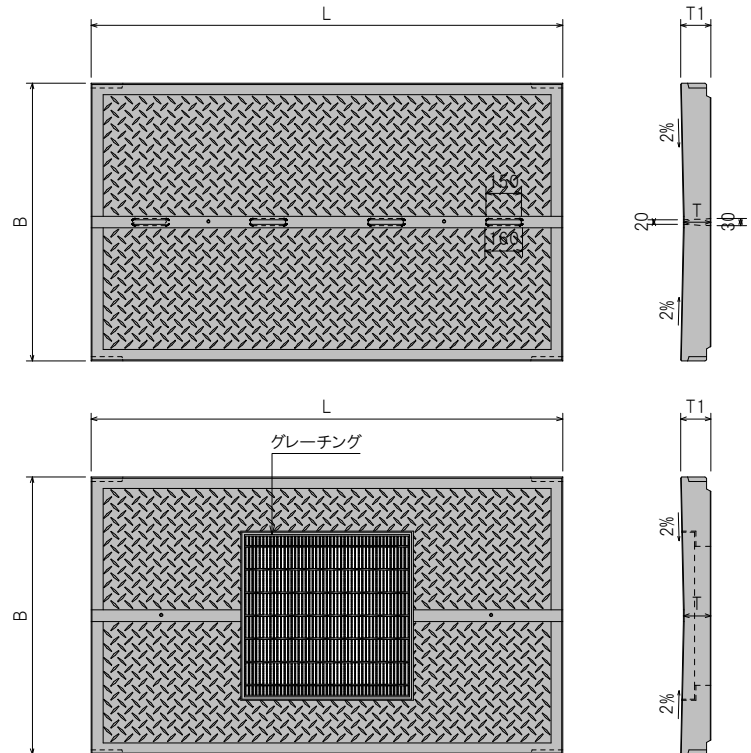
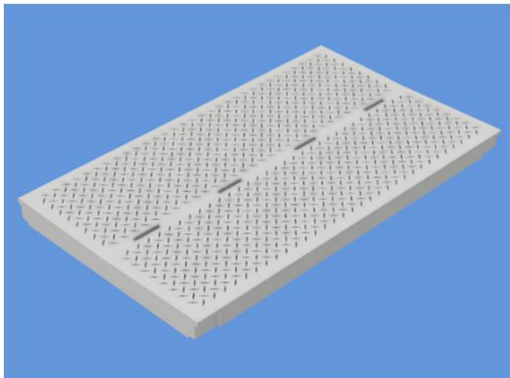

呼び名	参考重量(kg)		寸法 (mm)			
	標準	グレーチングタイプ	B	L	T	T1
700用	578	—	1000	2000	119	130
800用	640	—	1100	2000	119	130
900用	720	—	1200	2000	118	130
1000用	758	—	1300	2000	117	130
1200用	868	—	1500	2000	115	130

※スリットグレーチングタイプも製造可能です。

都市型
水路

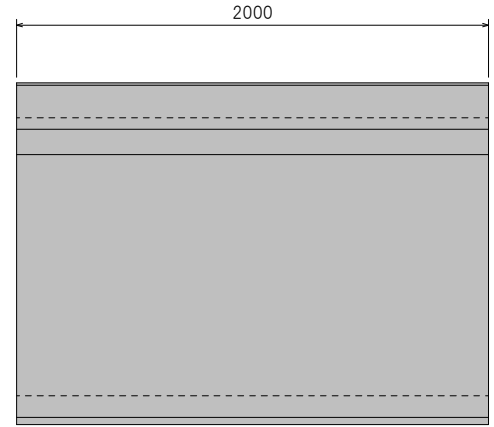
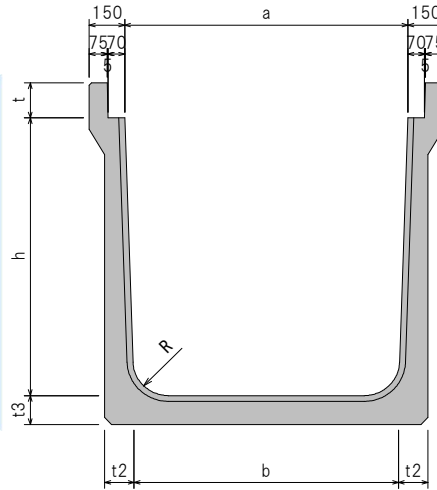
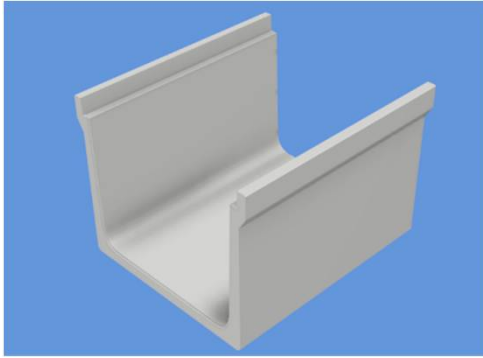

H=600

呼び名	参考重量 (kg)	寸法 (mm)						
		a	h	b	t	t2	t3	R
400×600	881	400	600	360	120	90	90	70
500×600	924	500	600	460	120	90	90	70
600×600	967	600	600	560	120	90	90	70
700×600	1010	700	600	660	120	90	90	70
800×600	1053	800	600	760	120	90	90	70
900×600	1096	900	600	860	120	90	90	70
1000×600	1162	1000	600	960	150	90	90	70
1100×600	1205	1100	600	1060	150	90	90	70
1200×600	1248	1200	600	1160	150	90	90	70

H=700

呼び名	参考重量 (kg)	寸法 (mm)						
		a	h	b	t	t2	t3	R
500×700	1040	500	700	450	120	95	95	100
600×700	1086	600	700	550	120	95	95	100
700×700	1132	700	700	650	120	95	95	100
800×700	1178	800	700	750	120	95	95	100
900×700	1224	900	700	850	120	95	95	100
1000×700	1290	1000	700	950	150	95	95	100
1100×700	1336	1100	700	1050	150	95	95	100
1200×700	1382	1200	700	1150	150	95	95	100
1300×700	1428	1300	700	1250	150	95	95	100
1400×700	1474	1400	700	1350	150	95	95	100
1500×700	1520	1500	700	1450	150	95	95	100
1600×700	1566	1600	700	1550	150	95	95	100
1700×700	1612	1700	700	1650	150	95	95	100
1800×700	1658	1800	700	1750	150	95	95	100
1900×700	1704	1900	700	1850	150	95	95	100
2000×700	1750	2000	700	1950	150	95	95	100

H=800

呼び名	参考重量 (kg)	寸法 (mm)						
		a	h	b	t	t2	t3	R
600×800	1165	600	800	550	120	95	95	100
700×800	1211	700	800	650	120	95	95	100
800×800	1257	800	800	750	120	95	95	100
900×800	1303	900	800	850	120	95	95	100
1000×800	1369	1000	800	950	150	95	95	100
1100×800	1415	1100	800	1050	150	95	95	100
1200×800	1461	1200	800	1150	150	95	95	100
1300×800	1507	1300	800	1250	150	95	95	100
1400×800	1553	1400	800	1350	150	95	95	100
1500×800	1599	1500	800	1450	150	95	95	100
1600×800	1645	1600	800	1550	150	95	95	100
1700×800	1691	1700	800	1650	150	95	95	100
1800×800	1737	1800	800	1750	150	95	95	100
1900×800	1783	1900	800	1850	150	95	95	100
2000×800	1829	2000	800	1950	150	95	95	100

H=900

呼び名	参考重量 (kg)	寸法 (mm)						
		a	h	b	t	t2	t3	R
600×900	1301	600	900	550	120	100	100	100
700×900	1349	700	900	650	120	100	100	100
800×900	1397	800	900	750	120	100	100	100
900×900	1445	900	900	850	120	100	100	100
1000×900	1516	1000	900	950	150	100	100	100
1100×900	1564	1100	900	1050	150	100	100	100
1200×900	1612	1200	900	1150	150	100	100	100
1300×900	1660	1300	900	1250	150	100	100	100
1400×900	1708	1400	900	1350	150	100	100	100
1500×900	1756	1500	900	1450	150	100	100	100
1600×900	1804	1600	900	1550	150	100	100	100
1700×900	1852	1700	900	1650	150	100	100	100
1800×900	1900	1800	900	1750	150	100	100	100
1900×900	1948	1900	900	1850	150	100	100	100
2000×900	1996	2000	900	1950	150	100	100	100

※蓋のかかり部分を取って「大型フリューム」として製造可能です。設置条件によって、底部の厚みが異なりますので、各営業所にお問い合わせください。

H=1000

呼び名	参考重量 (kg)	寸法 (mm)						
		a	h	b	t	t2	t3	R
700×1000	1545	700	1000	630	120	110	110	150
800×1000	1598	800	1000	730	120	110	110	150
900×1000	1651	900	1000	830	120	110	110	150
1000×1000	1726	1000	1000	930	150	110	110	150
1100×1000	1779	1100	1000	1030	150	110	110	150
1200×1000	1832	1200	1000	1130	150	110	110	150
1300×1000	1885	1300	1000	1230	150	110	110	150
1400×1000	1938	1400	1000	1330	150	110	110	150
1500×1000	1991	1500	1000	1430	150	110	110	150
1600×1000	2044	1600	1000	1530	150	110	110	150
1700×1000	2097	1700	1000	1630	150	110	110	150
1800×1000	2150	1800	1000	1730	150	110	110	150
1900×1000	2203	1900	1000	1830	150	110	110	150
2000×1000	2256	2000	1000	1930	150	110	110	150

H=1100

呼び名	参考重量 (kg)	寸法 (mm)						
		a	h	b	t	t2	t3	R
800×1100	1760	800	1100	730	120	115	115	150
900×1100	1815	900	1100	830	120	115	115	150
1000×1100	1893	1000	1100	930	150	115	115	150
1100×1100	1948	1100	1100	1030	150	115	115	150
1200×1100	2003	1200	1100	1130	150	115	115	150
1300×1100	2058	1300	1100	1230	150	115	115	150
1400×1100	2113	1400	1100	1330	150	115	115	150
1500×1100	2168	1500	1100	1430	150	115	115	150
1600×1100	2223	1600	1100	1530	150	115	115	150
1700×1100	2278	1700	1100	1630	150	115	115	150
1800×1100	2333	1800	1100	1730	150	115	115	150
1900×1100	2388	1900	1100	1830	150	115	115	150
2000×1100	2443	2000	1100	1930	150	115	115	150

H=1200

呼び名	参考重量 (kg)	寸法 (mm)						
		a	h	b	t	t2	t3	R
800×1200	1985	800	1200	720	120	125	125	150
900×1200	2045	900	1200	820	120	125	125	150
1000×1200	2127	1000	1200	920	150	125	125	150
1100×1200	2187	1100	1200	1020	150	125	125	150
1200×1200	2247	1200	1200	1120	150	125	125	150
1300×1200	2307	1300	1200	1220	150	125	125	150
1400×1200	2367	1400	1200	1320	150	125	125	150
1500×1200	2427	1500	1200	1420	150	125	125	150
1600×1200	2487	1600	1200	1520	150	125	125	150
1700×1200	2547	1700	1200	1620	150	125	125	150
1800×1200	2607	1800	1200	1720	150	125	125	150
1900×1200	2667	1900	1200	1820	150	125	125	150
2000×1200	2727	2000	1200	1920	150	125	125	150
2100×1200	2809	2100	1200	2020	180	125	125	150
2200×1200	2869	2200	1200	2120	180	125	125	150

H=1300

呼び名	参考重量 (kg)	寸法 (mm)						
		a	h	b	t	t2	t3	R
900×1300	2383	900	1300	810	120	140	140	150
1000×1300	2473	1000	1300	910	150	140	140	150
1100×1300	2540	1100	1300	1010	150	140	140	150
1200×1300	2607	1200	1300	1110	150	140	140	150
1300×1300	2674	1300	1300	1210	150	140	140	150
1400×1300	2741	1400	1300	1310	150	140	140	150
1500×1300	2808	1500	1300	1410	150	140	140	150
1600×1300	2875	1600	1300	1510	150	140	140	150
1700×1300	2942	1700	1300	1610	150	140	140	150
1800×1300	3009	1800	1300	1710	150	140	140	150
1900×1300	3076	1900	1300	1810	150	140	140	150
2000×1300	3143	2000	1300	1910	150	140	140	150
2100×1300	3234	2100	1300	2010	180	140	140	150
2200×1300	3301	2200	1300	2110	180	140	140	150
2300×1300	3368	2300	1300	2210	180	140	140	150

H=1400

呼び名	参考重量 (kg)	寸法 (mm)						
		a	h	b	t	t2	t3	R
1000×1400	2783	1000	1400	910	150	150	150	150
1100×1400	2855	1100	1400	1010	150	150	150	150
1200×1400	2927	1200	1400	1110	150	150	150	150
1300×1400	2999	1300	1400	1210	150	150	150	150
1400×1400	3071	1400	1400	1310	150	150	150	150
1500×1400	3143	1500	1400	1410	150	150	150	150
1600×1400	3215	1600	1400	1510	150	150	150	150
1700×1400	3287	1700	1400	1610	150	150	150	150
1800×1400	3359	1800	1400	1710	150	150	150	150
1900×1400	3431	1900	1400	1810	150	150	150	150
2000×1400	3503	2000	1400	1910	150	150	150	150
2100×1400	3598	2100	1400	2010	180	150	150	150
2200×1400	3670	2200	1400	2110	180	150	150	150
2300×1400	3742	2300	1400	2210	180	150	150	150
2400×1400	3814	2400	1400	2310	180	150	150	150

H=1500

呼び名	参考重量 (kg)	寸法 (mm)						
		a	h	b	t	t2	t3	R
1000×1500	3152	1000	1500	900	150	160	160	250
1100×1500	3229	1100	1500	1000	150	160	160	250
1200×1500	3306	1200	1500	1100	150	160	160	250
1300×1500	3383	1300	1500	1200	150	160	160	250
1400×1500	3460	1400	1500	1300	150	160	160	250
1500×1500	3537	1500	1500	1400	150	160	160	250
1600×1500	3614	1600	1500	1500	150	160	160	250
1700×1500	3691	1700	1500	1600	150	160	160	250
1800×1500	3768	1800	1500	1700	150	160	160	250
1900×1500	3845	1900	1500	1800	150	160	160	250
2000×1500	3922	2000	1500	1900	150	160	160	250
2100×1500	4019	2100	1500	2000	180	160	160	250
2200×1500	4096	2200	1500	2100	180	160	160	250
2300×1500	4173	2300	1500	2200	180	160	160	250
2400×1500	4250	2400	1500	2300	180	160	160	250
2500×1500	4327	2500	1500	2400	180	160	160	250
2600×1500	4404	2600	1500	2500	180	160	160	250
2700×1500	4481	2700	1500	2600	180	160	160	250

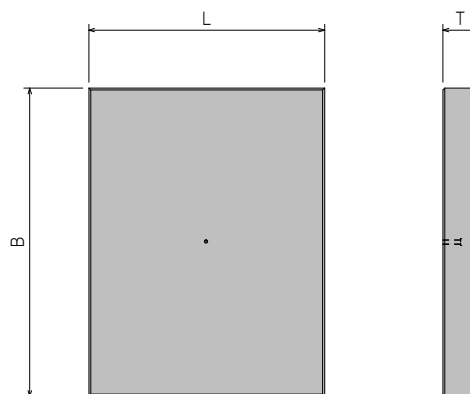
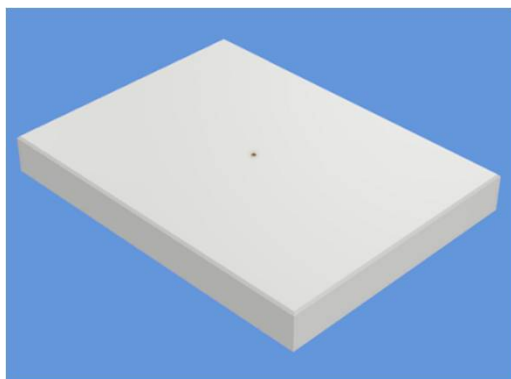

呼び名	参考重量 (kg)	寸 法 (mm)		
		B	L	T
600 用	210	730	1000	120
700 用	239	830	1000	120
800 用	268	930	1000	120
900 用	297	1030	1000	120
1000 用	406	1130	1000	150
1100 用	443	1230	1000	150
1200 用	479	1330	1000	150
1300 用	515	1430	1000	150
1400 用	551	1530	1000	150
1500 用	587	1630	1000	150
1600 用	623	1730	1000	150
1700 用	659	1830	1000	150
1800 用	695	1930	1000	150
1900 用	731	2030	1000	150
2000 用	767	2130	1000	150
2100 用	963	2230	1000	180
2200 用	1007	2330	1000	180
2300 用	1050	2430	1000	180
2400 用	1093	2530	1000	180
2500 用	1136	2630	1000	180
2600 用	1179	2730	1000	180
2700 用	1223	2830	1000	180

長尺U字溝 KUS・KUR

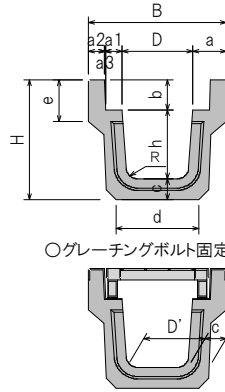

○グレーチングボルト固定タイプ

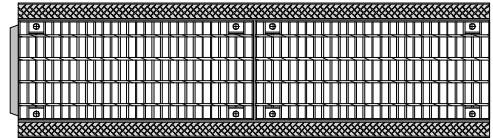
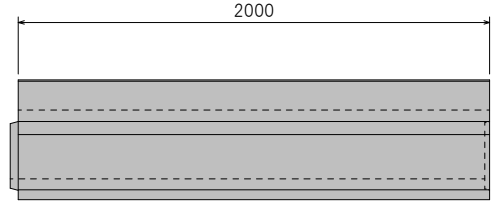
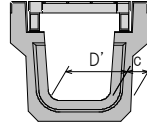

呼び名	参考重量 (kg)	寸 法 (mm)														
		B	H	D	D'	h	a	a1	a2	a3	b	c	d	e	R	
K	250×250	297	480	405	250	230	250	115	62	50	3	100	55	270	130	50
	300×300	356	545	460	300	260	300	122.5	67.5	50	5	100	60	300	130	50
	300×400	479	565	570	300	250	400	132.5	67.5	60	5	100	70	300	134	50
U	350×350	430	605	515	350	305	350	127.5	67.5	55	5	100	65	350	132	50
	350×400	496	615	570	350	300	400	132.5	67.5	60	5	100	70	350	134	50
S	400×400	516	665	570	400	350	400	132.5	67.5	60	5	100	70	400	134	70
	400×500	626	675	675	400	335	500	137.5	67.5	65	5	100	75	400	136	70
	250×250	325	480	425	250	230	250	115	62	50	3	100	75	270	130	50
K	300×300	556	585	520	300	260	300	142.5	67.5	70	5	130	90	350	180	50
	300×400	715	605	630	300	250	400	152.5	67.5	80	5	130	100	350	184	50
U	350×350	655	645	575	350	305	350	147.5	67.5	75	5	130	95	400	182	50
	350×400	738	655	630	350	300	400	152.5	67.5	80	5	130	100	400	184	50
R	400×400	766	705	630	400	350	400	152.5	67.5	80	5	130	100	450	184	70
	400×500	951	725	740	400	335	500	162.5	67.5	90	5	130	110	450	189	70

※グレーチングボルト固定タイプは受注生産となります。

長尺BOX型側溝

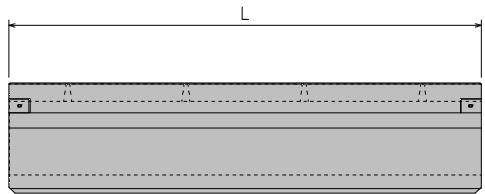
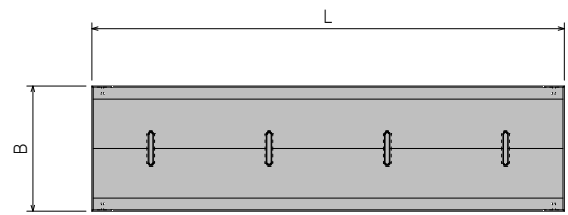
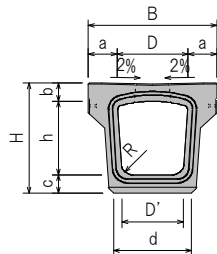
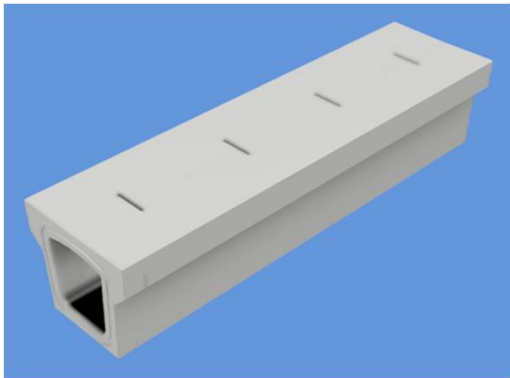

呼び名	参考重量 (kg)	寸 法 (mm)										
		B	H	D	D'	h	a	L	b	c	d	R
KUB 300×300	599	545	480	300	260	320	122.5	1998	80	80	330	50

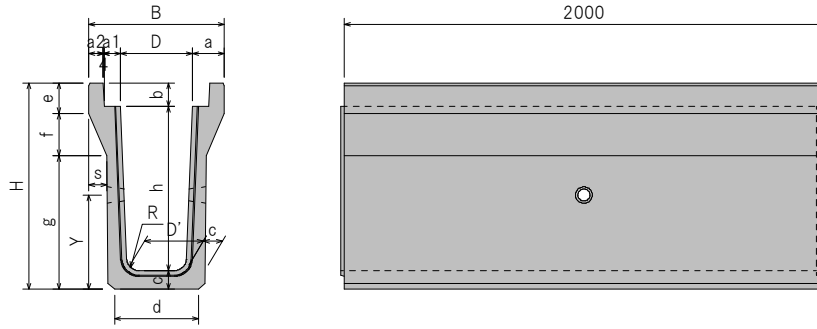

呼び名	参考重量 (kg)	寸法 (mm)																	
		B	H	D	D'	h	d	a	a1	a2	b	c	e	f	g	s	R	Y	
K	300×500	598	565	675	300	260	500	359	132.5	68.5	60	100	75	130	180	365	75	50	304
	300×600	663	565	775	300	252	600	350	132.5	68.5	60	100	75	130	180	465	75	50	355
	300×700	755	565	880	300	244	700	352	132.5	68.5	60	100	80	130	180	570	75	50	402
	300×800	852	565	985	300	236	800	355	132.5	68.5	60	100	85	130	180	675	75	50	448
	300×900	951	565	1090	300	228	900	357	132.5	68.5	60	100	90	130	180	780	75	50	492
D	300×1000	1057	565	1195	300	220	1000	359	132.5	68.5	60	100	95	130	180	885	75	50	536
	400×600	725	675	775	400	352	600	448	137.5	68.5	65	100	75	130	180	465	75	70	343
	400×700	822	675	880	400	344	700	451	137.5	68.5	65	100	80	130	180	570	75	70	390
	400×800	923	675	985	400	336	800	453	137.5	68.5	65	100	85	130	180	675	75	70	435
S	400×900	1027	675	1090	400	328	900	456	137.5	68.5	65	100	90	130	180	780	75	70	479
	400×1000	1139	675	1195	400	320	1000	458	137.5	68.5	65	100	95	130	180	885	75	70	523
	300×500	892	605	740	300	260	500	428	152.5	68.5	80	130	110	170	170	400	65	50	321
	300×600	979	605	840	300	252	600	421	152.5	68.5	80	130	110	170	170	500	65	50	370
K	300×700	1073	605	940	300	244	700	412	152.5	68.5	80	130	110	170	170	600	65	50	420
	300×800	1172	605	1040	300	236	800	402	152.5	68.5	80	130	110	170	170	700	65	50	470
	300×900	1304	605	1145	300	228	900	405	152.5	68.5	80	130	115	170	170	805	65	50	517
D	300×1000	1470	605	1255	300	220	1000	419	152.5	68.5	80	130	125	170	170	915	65	50	559
	400×600	1082	725	840	400	352	600	516	162.5	68.5	90	130	110	170	170	500	65	70	363
	400×700	1182	725	940	400	344	700	507	162.5	68.5	90	130	110	170	170	600	65	70	413
	400×800	1285	725	1040	400	336	800	499	162.5	68.5	90	130	110	170	170	700	65	70	462
R	400×900	1425	725	1145	400	328	900	502	162.5	68.5	90	130	115	170	170	805	65	70	509
	400×1000	1600	725	1250	400	320	1000	516	162.5	68.5	90	130	120	170	170	915	65	70	552

※グレーチングボルト固定タイプも製造可能です。(受注生産)

側溝用ふた

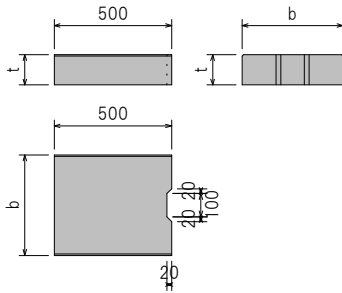

呼び名	参考重量 (kg)	寸法 (mm)	
		b	t
250用	43	370	100
IS 300	51	430	100
IS 400	63	530	100
IR 300	67	430	130
IR 400	83	530	130

側溝用ふた

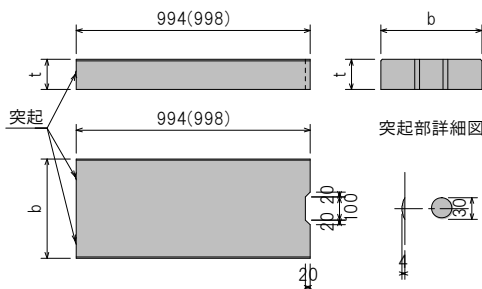

呼び名	参考重量 (kg)	寸法 (mm)	
		b	t
250用	87	370	100
ISL 300	101	430	100
ISL 350	113	480	100
ISL 400	125	530	100
IRL 300	132	430	130
IRL 350	148	480	130
IRL 400	163	530	130

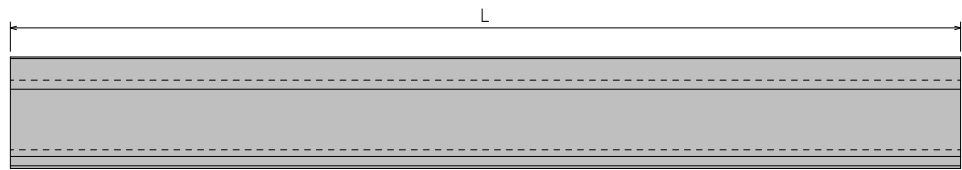
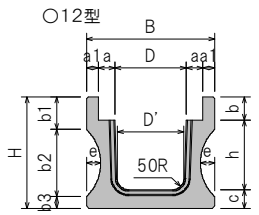
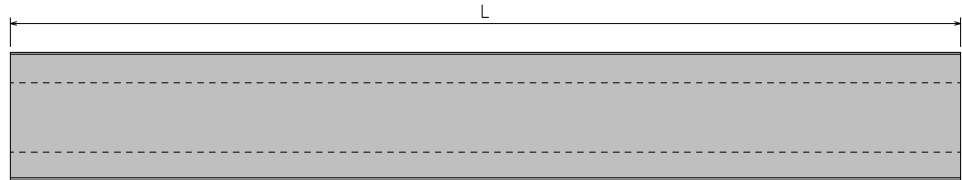
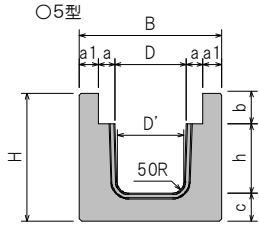
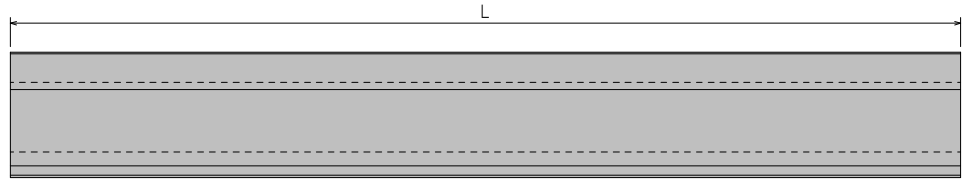
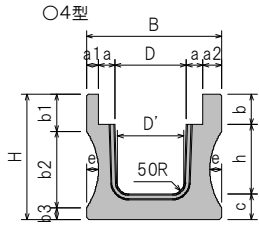

○グレーチングボルト固定タイプ

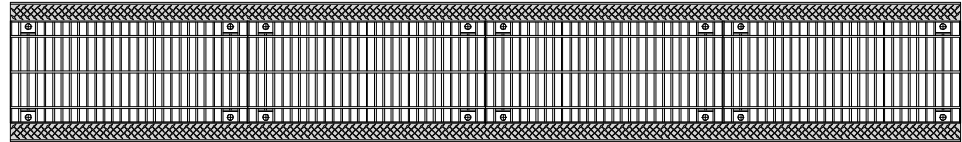
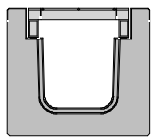

呼び名		参考重量 (kg)	寸法 (mm)														
			B	H	D	D'	h	a	a1	a2	b	b1	b2	b3	c	e	L
4型	300×300	1320	570	540	300	280	300	70	50	80	130	160	330	50	110	50	4000
	300×400	1520	570	640	300	280	400	70	50	80	130	170	420	50	110	50	4000
	300×500	1730	570	740	300	280	500	70	50	80	130	190	500	50	110	50	4000
	400×400	1620	670	640	400	380	400	70	50	80	130	170	420	50	110	50	4000
	400×500	1830	670	740	400	380	500	70	50	80	130	180	510	50	110	50	4000
	500×500	2020	770	770	500	480	500	70	50	80	150	190	520	50	120	50	4000
500×600	1750	770	880	500	470	600	70	50	80	150	190	640	50	130	50	3000	
5型	300×300	1780	600	550	300	280	300	70	80	—	130	—	—	—	120	—	4000
	300×400	2073	600	650	300	280	400	70	80	—	130	—	—	—	120	—	4000
	300×500	2370	600	750	300	280	500	70	80	—	130	—	—	—	120	—	4000
	400×400	2188	700	650	400	380	400	70	80	—	130	—	—	—	120	—	4000
	400×500	1860	700	750	400	380	500	70	80	—	130	—	—	—	120	—	3000
	500×500	1970	800	770	500	480	500	70	80	—	150	—	—	—	120	—	3000
500×600	2363	800	900	500	470	600	70	80	—	150	—	—	—	150	—	3000	
12型	300×300	943	540	480	300	280	300	70	50	—	100	140	290	50	80	60	4000
	300×400	1120	540	580	300	280	400	70	50	—	100	140	390	50	80	60	4000
	300×500	1440	540	700	300	280	500	70	50	—	100	140	490	70	100	50	4000
	400×400	1310	640	600	400	380	400	70	50	—	100	140	390	70	100	60	4000
	400×500	1530	640	700	400	380	500	70	50	—	100	140	490	70	100	50	4000
	500×500	1640	740	720	500	480	500	70	50	—	120	160	490	70	100	50	4000
500×600	1750	800	840	500	470	600	70	80	—	120	120	630	90	120	60	3000	

※グレーチングボルト固定タイプは受注生産となります。

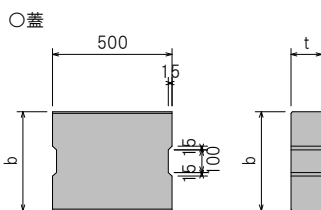

	呼び名	参考重量 (kg)	寸法 (mm)	
			b	t
歩道用	C ₇ B-300	51	430	100
	C ₇ B-400	62	530	100
	C ₇ B-500	88	630	120

	呼び名	参考重量 (kg)	寸法 (mm)	
			b	t
車道用	C ₇ B-300	65	430	130
	C ₇ B-400	81	530	130
	C ₇ B-500	111	630	150

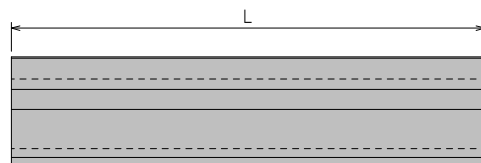
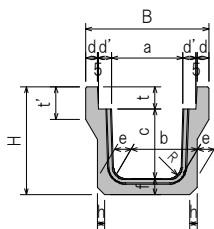
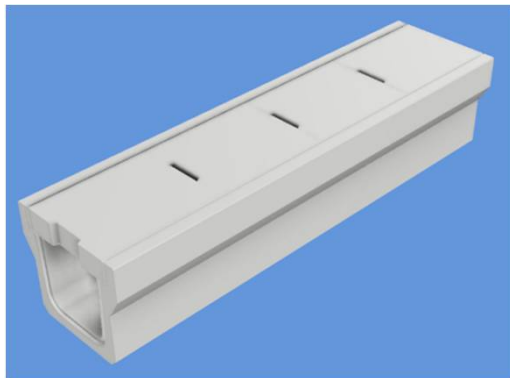

種類	呼び名	参考重量 (kg)	寸 法 (mm)													
			B	H	a	b	c	d	d'	e	f	h	t	t'	R	L
1 種	300A	346	500	455	300	280	300	40	55	60	60	20	95	120	50	2000
	300B	416	500	560	300	270	400	40	55	65	65	20	95	120	50	2000
	300C	496	500	665	300	260	500	40	55	70	70	20	95	120	50	2000
	400A	451	600	575	400	370	400	40	55	65	65	20	110	135	50	2000
	400B	531	600	680	400	360	500	40	55	70	70	20	110	135	50	2000
	400C	598	600	785	400	350	600	40	55	75	75	20	110	135	50	2000
	500A	576	720	695	500	460	500	45	60	70	70	20	125	150	50	2000
	500B	666	720	800	500	450	600	45	60	75	75	20	125	150	50	2000
	500C	728	720	900	500	450	700	45	60	75	75	20	125	150	50	2000
3 種	300A	416	520	465	300	280	300	50	55	70	70	30	95	140	50	2000
	300B	468	520	565	300	270	400	50	55	70	70	40	95	140	50	2000
	300C	581	520	675	300	260	500	50	55	80	80	40	95	140	50	2000
	400A	505	630	580	400	370	400	55	55	70	70	40	110	140	50	2000
	400B	626	630	690	400	360	500	55	55	80	80	40	110	140	50	2000
	400C	747	630	800	400	350	600	55	55	90	90	40	110	140	50	2000
	500A	685	750	705	500	460	500	60	60	80	80	40	125	155	50	2000
	500B	835	750	815	500	450	600	60	60	90	90	40	125	175	50	2000
	500C	902	750	915	500	450	700	60	60	90	90	40	125	175	50	2000

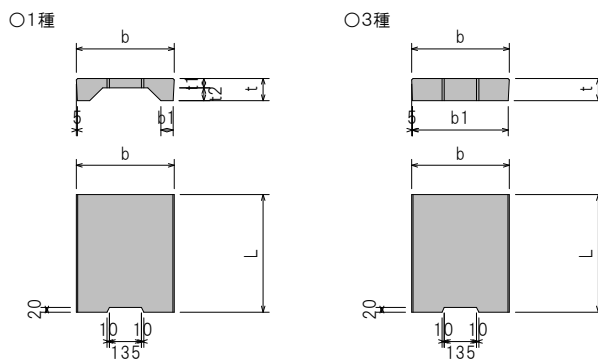

種類	呼び名	参考重量 (kg)	寸 法 (mm)					
			b	b1	t	t1	t2	L
1 種	300	33	412	51	95	55	40	500
	400	47	512	51	110	65	45	500
	500	65	622	56	125	75	50	500
3 種	300	45	412	402	95	—	—	500
	400	65	512	502	110	—	—	500
	500	91	622	612	125	—	—	500

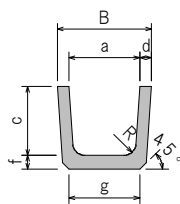
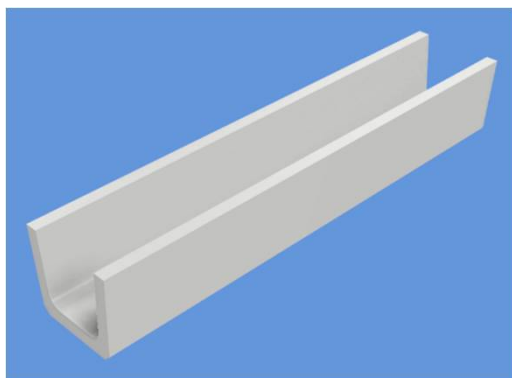

種類	呼び名	参考重量 (kg)	寸法 (mm)									
			B	a	b	c	d	e	f	g	R	L
1種	300B	263	400	300	260	300	50	60	60	300	50	2000
2種	300B	263	400	300	260	300	50	60	60	300	50	2000